

Quickdraw®

SYSTEMS

XR Conveyor Maintenance Guide

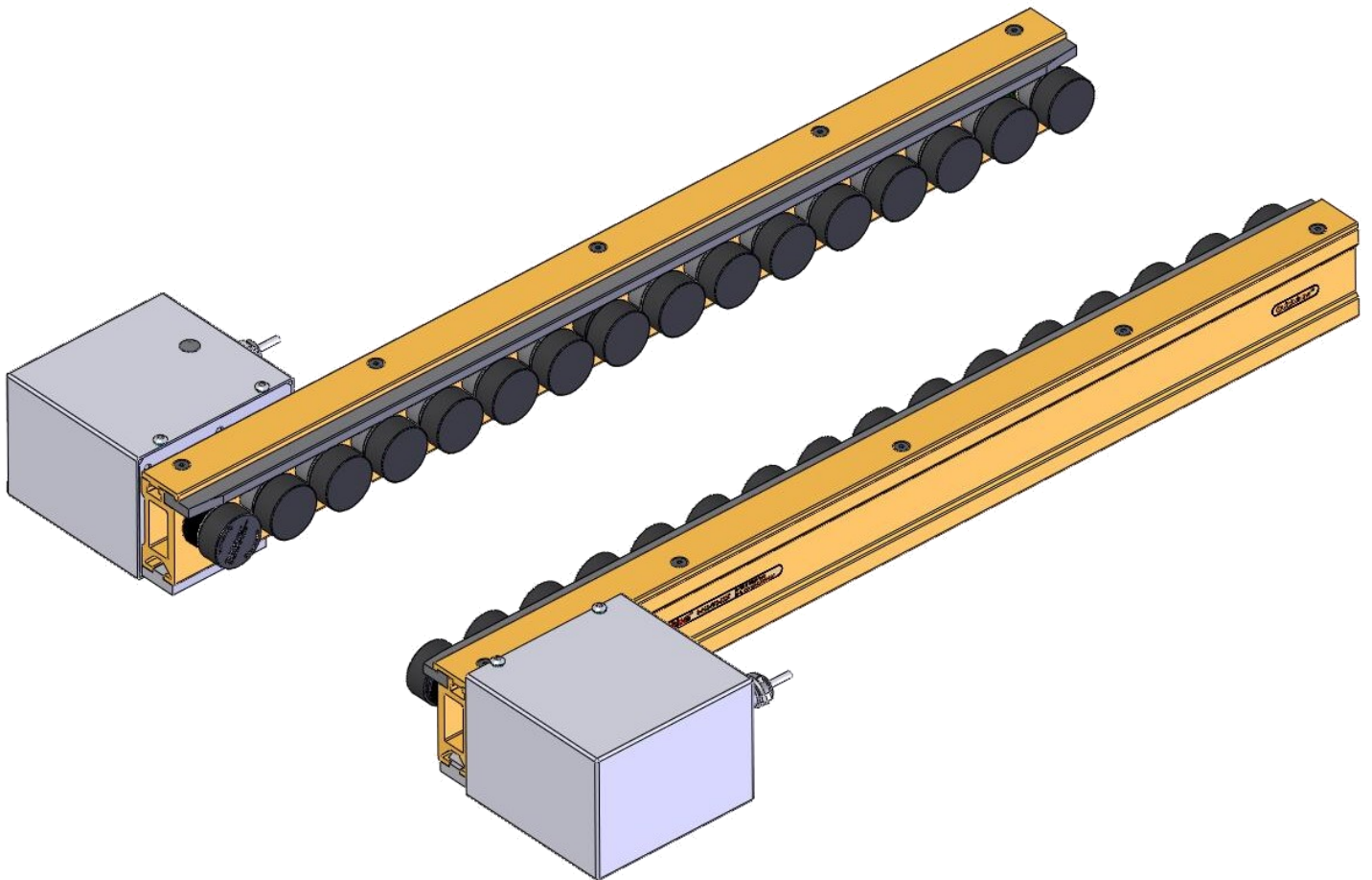

Table of Contents

• Overview	Page 3
• XR Conveyor Assembly General Information	Page 4
• Exploded View of an XR Conveyor	Page 5
• Maintenance	Pages 6-9
Routine Maintenance	Page 6
Powering Conveyors By Hand	Page 6
Removing Rollers using Fork Tool	Page 7
Standard Roller Assembly Diagram	Page 8
Drive Roller Assembly Diagram	Page 8
Belt Tensioning Assembly Diagram	Page 8
Belt Tensioning Procedure	Page 9
Motor Replacement	Page 10
Timing Belt & Product Guide Replacement	Page 11
• Electrical Controls Maintenance	Pages 12-20
Measuring Current Draw	Page 12
Integral Motor Control Card	Pages 13-16
Changing Conveyor Flow Direction	Pages 15 & 17
Motor Card Wiring Diagram	Page 17
Setting Conveyor Speeds	Page 18
Phase Considerations	Page 19
Electrical Troubleshooting	Page 20
• Troubleshooting	Page 21
• XR Conveyor Parts List	Page 22

Overview

Quickdraw Conveyors are designed to be the most reliable and easiest to maintain automated process conveyors available. This Guide consists of easy to understand maintenance procedures for your XR Series Conveyor. This Guide also contains a Troubleshooting Section to help technicians identify the potential causes of any problems that may occur.

If you require any assistance, technical support or have any questions, please contact Quickdraw's Customer Service Department at:

Quickdraw Systems

Phone: 1-800-473-8837
(952) 935-6921

Fax: (952) 933-5803

Internet: www.qdraw.com
E-mail: info@qdraw.com

Or, write to us at:

**Quickdraw Systems
700 Industrial Circle S.
Shakopee, MN 55379-1897**

Note: Some illustrations in this manual include features that may not match or be included on your conveyor system.

Note: This maintenance manual is offered in the English language. If other languages are required, Quickdraw is not responsible for translation.

XR Conveyor Assembly

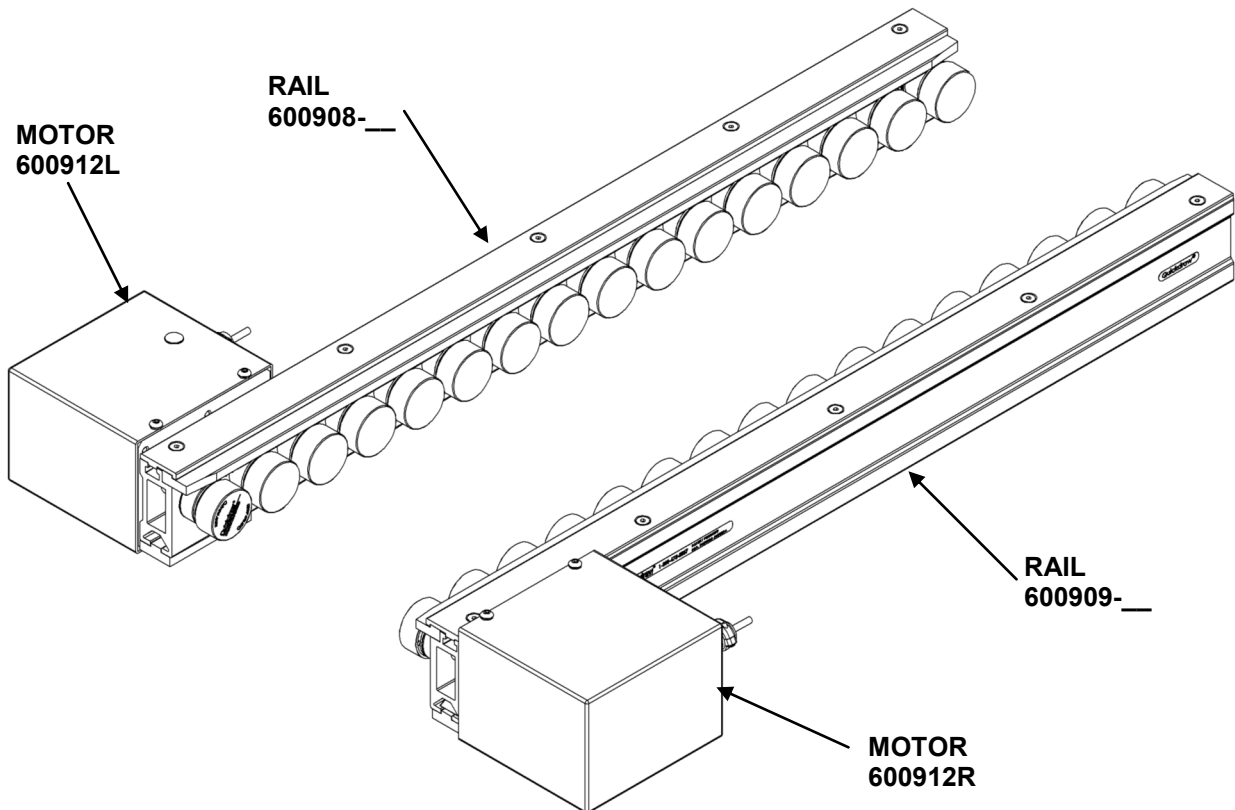

XR Conveyor Basic Parts

General Information:

XR conveyors are simply, yet durably constructed. They come available in 1.5" increments from as short as 7.5" to as long as 120". Distance between product guides is recommended to be .06" over the width of the item transported. So, a 5" pallet would need 5.06" between the guides. Talk with Sales and Service if you need to vary from this distance.

Rollers are 1.25" in diameter and spaced 1.5" apart. They are .75" from each end with some variation possible at the tensioning end.

Motors are mounted in a "Direct Drive" fashion so that the shaft is coupled directly to the drive roller assembly. There is no drive belt. A motor can be reassembled to work on the opposite side.

Timing Belts are Steel reinforced 10 mm wide x 5 mm pitch.

Typical XR Conveyor Assembly

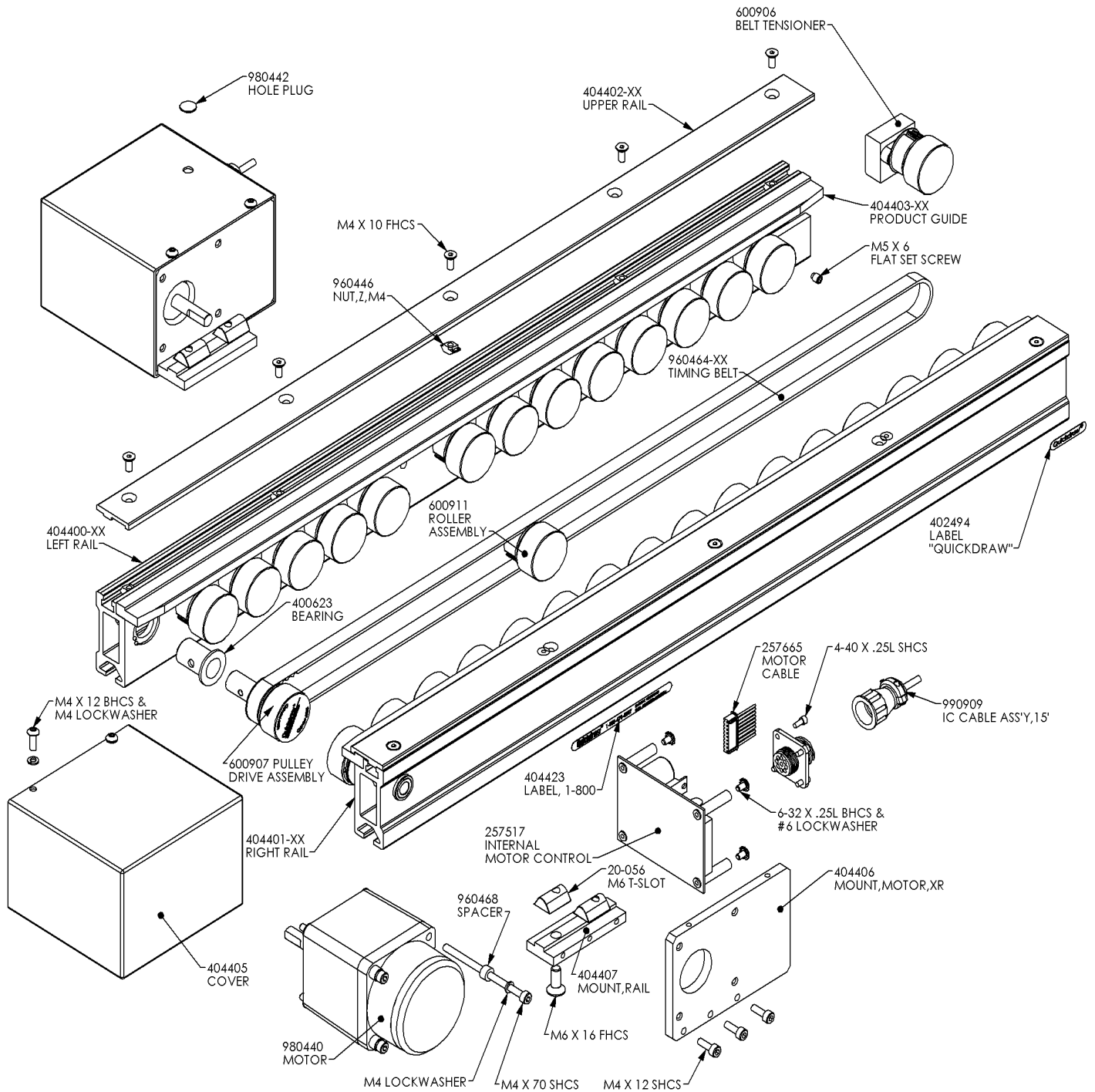

Routine Maintenance

The following is a list of procedures that should be followed as a part of a regular maintenance routine.

Procedure For XR Conveyors:

Check the Conveyor to make sure that all rollers are turning freely.
Check for wear on the Timing Belts.
Check to make sure that the Conveyor is securely fastened to its frame.
Always hand-power the Conveyors after maintenance and before start-up.

Powering Conveyors By Hand

Powering the Conveyor by hand must be done during Product Guide replacement and after every maintenance procedure prior to connecting the power source. This is done to ensure that the Timing Belts are seated properly onto the teeth of the pulleys.

***Important:** Failure to hand-power a conveyor before turning on its motor may result in the following:*

- 1) Blown Fuse*
- 2) Timing Belt Damage*
- 3) Drive Assembly Damage*

Procedure:

- 1) Turn the Drive Pulley with your fingers. Turn in both directions until the Timing Belts are properly seated. *The last direction turned should be the same as the conveyor's direction of flow.
- 2) To avoid problems, hand-power the conveyor as it is being assembled. *For example:* After assembling the Drive system, hand-power the conveyor. After replacing the Product Guide, hand-power the conveyor.

Removing Rollers Using Fork Tool

Procedure:

- 1) Wear safety glasses. To access Roller Shaft's hex socket, remove the Roller using the Fork Tool. Insert tool, flat side away from Roller, between Roller and Pulley. Push straight down until the wedge forces the Roller over a bump on the Pulley. The Roller may shoot off with some force so use caution. Use light taps with a small hammer and be ready to catch the roller. Note: It is best to push straight down as prying may damage Roller, Pulley and Tool. Normally undamaged, parts may be re-used.

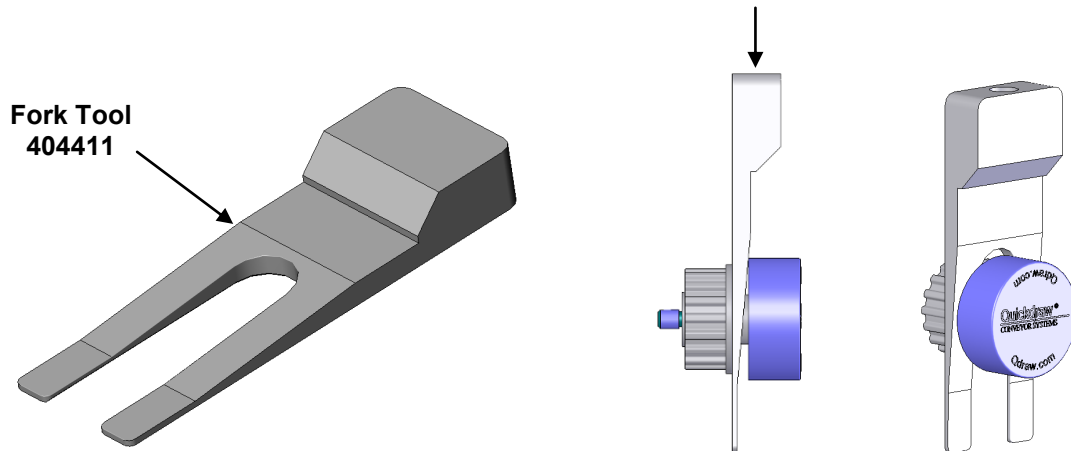

Standard Roller Assembly #600911

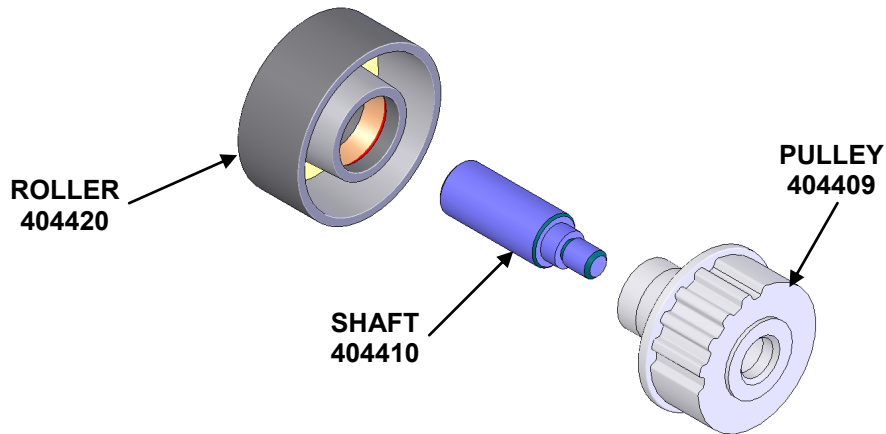

Drive Roller Assembly #600907

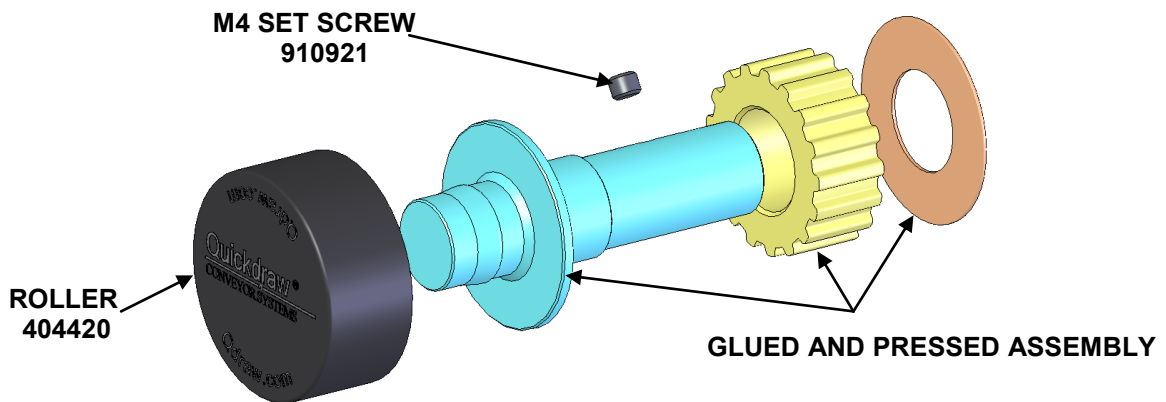

Belt Tensioning Assembly #600906

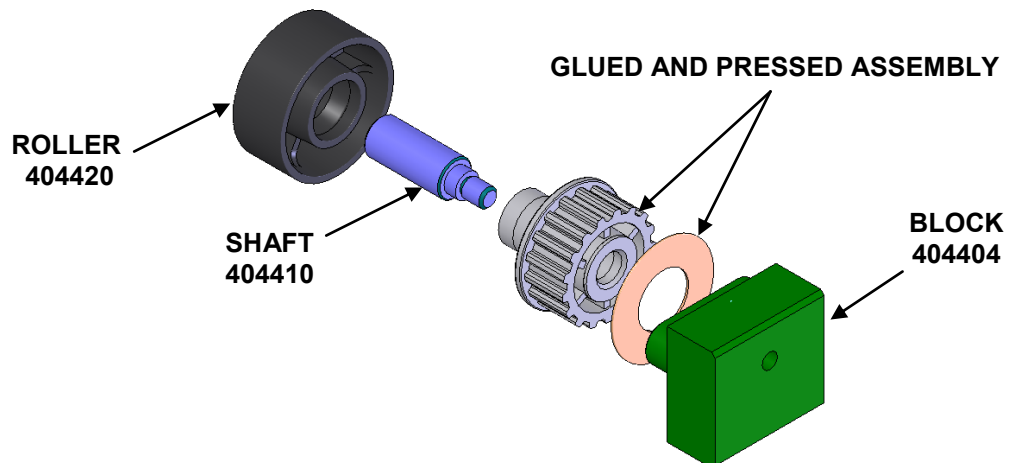

Belt Tension

Important: Over-tension of the belts on the XR system may cause increased wear on the drive components of the system. The tensioners on this conveyor are only supplied to take up slack and are not intended to increase belt pulley engagement.

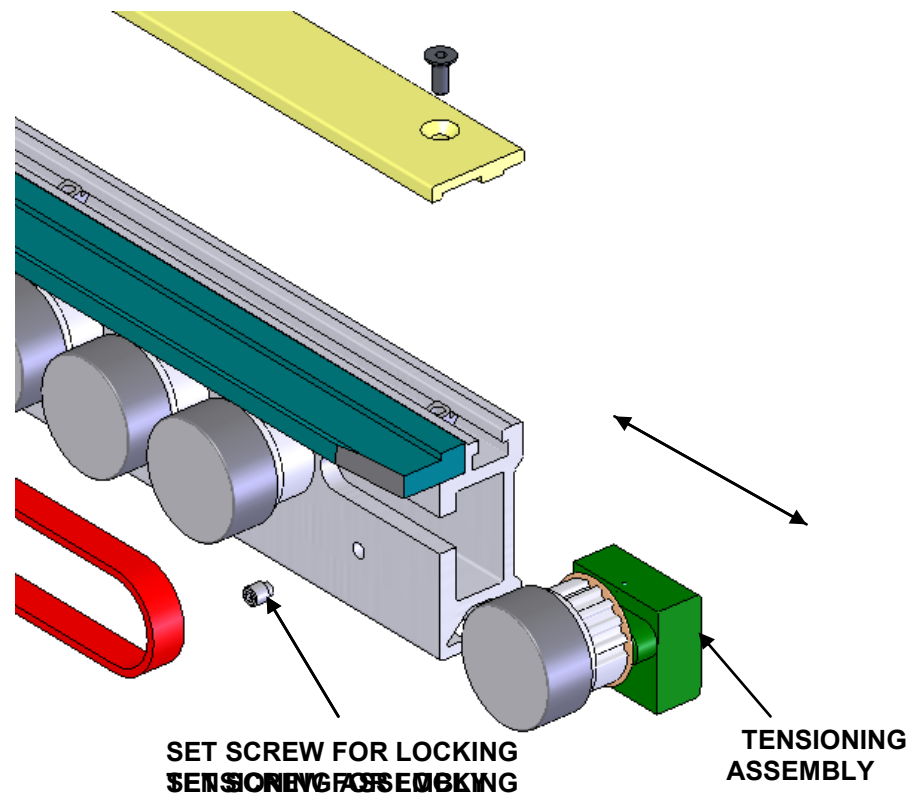

Procedure:

- 1) Loosen the set screw securing the belt tensioner at the end of the rail opposite the drive side.
- 2) With belt teeth fully engaged, pull tensioner by hand to take the slack out of the belt. **Do not use anything to pry the tensioner, tension should be only hand tight.** Also see Powering Conveyors By Hand on Page 6.
- 3) Tighten the Set Screw to lock the tensioning block into place. Look through the end of the rail to be sure the tensioner is pressed flat against the opposite wall of the extrusion.

Motor Replacement

Procedure : (you will need access to the open end of the rail)

- 1) Turn off Power to the Conveyor.
- 2) Loosen the belt tensioner to relieve tension on the timing belt (See Page 9).
- 3) Unplug the Motor Cable from the Motor and remove the motor cover.
- 4) Disconnect all cables from the motor's connectors.
- 5) Look at the motor end of the rail extrusion. Rotate the pulley by hand by moving the timing belt until the set screw is visible through the access hole in the sleeve bearing. Remove the set-screw that connects the motor to the Pulley Drive Shaft.
- 6) Remove the four M4 screws that secure the Motor to the Motor Bracket.
- 7) Remove the Motor.
- 8) Before installing the new motor, rotate it's shaft until the flat on the shaft lines up with the set screw access hole. Install the new Motor to the Motor Bracket with the four screws.
- 9) Install the set screw, making sure it squarely engages the flat on the motor shaft.
- 10) Re-tension the timing belt (See Page 9).
- 11) Hand Power the Conveyor (See Page 6).
- 12) Plug the Motor Cables into the Motor and replace the motor cover.
- 13) Turn on the Conveyor.

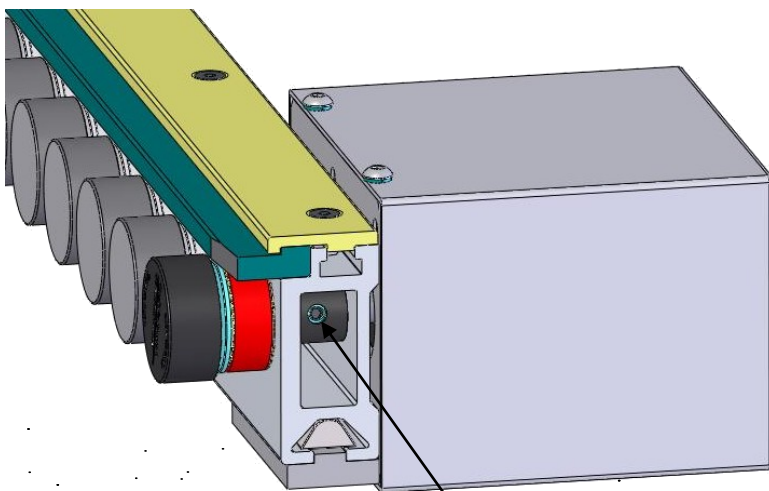

MOTOR SHAFT SET SCREW
AS SEEN THROUGH THE ACCESS
HOLE.

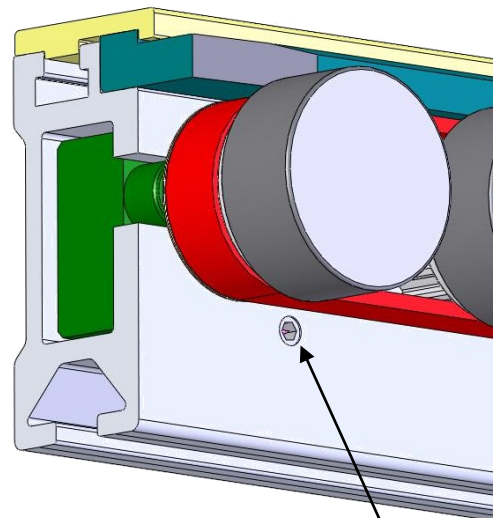

BELT TENSION SET SCREW

Timing Belt & Product Guide Replacement

Procedure:

- 1) To remove the Product Guide loosen the flat head screws, located along the top of the conveyor rail, just enough to slide the product guide out from under the Top Rail.
Note: The Top Rail is held with Z-Nuts and can be lifted free when they are loosened. However, they must be correctly re-installed.
- 1) Loosen the belt tensioner (See Page 9).
- 2) Remove the old Timing Belt.
- 3) Place the new Timing Belt over the Tensioner end pulley. * *Make sure that the belt is on the teeth of the Pulley.*
- 4) Pull the Belt toward the Motor end until it is around all of the pulleys on the conveyor, including the Drive Pulley on the Motor end.
- 5) Check the Timing Belt to ensure that it is not twisted or caught on the Rail.
- 6) Re-tension the belt using the tensioner opposite the motor (See Page 9).
- 7) Replace the Product Guide. If the top rail comes completely out of it's channel, care must be taken to re-seat the top rail completely into the groove and the Zee nuts must engage under the groove's lip. As you do this, keep checking the belt engagement into all the pulley teeth. Hold the Top Rail and the Product Guide against the Lower Rail per diagram as you tighten the fasteners.
- 8) Hand-Power the Conveyor (See Page 6).
- 9) Turn on the Conveyor.

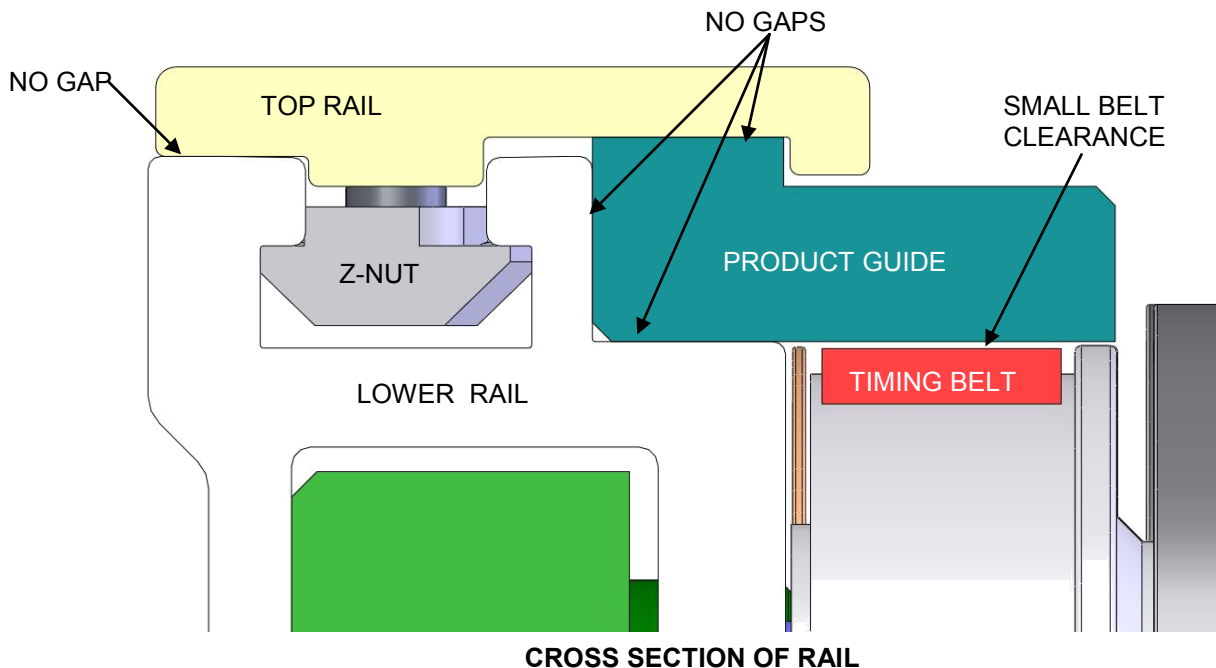

Electrical Controls Maintenance

Measuring Current Draw

Procedure:

Warning: This procedure describes testing in an open, powered Control Panel. Use caution.

- 1) In the Control Panel, open the Fuse Cover on the Fuse segment for that specific Conveyor. Opening the cover removes the fuse from the circuit.
- 2) With power on, carefully place the Ammeter's Probes on the screw heads as indicated in the diagram. The conveyor will "turn on". Take a reading on the meter.
- 3) If the reading is negative, reverse the probes.
- 4) The reading on a standard MR conveyor (unloaded - no product or pallet resistance) should be less than or equal to 0.75 amps.
- 5) If the reading exceeds this, see the Trouble Shooting -High Current section of this Manual on page #21.
- 6) Remove the Ammeter and close the Fuse segment cover. Close the Control Panel cover.

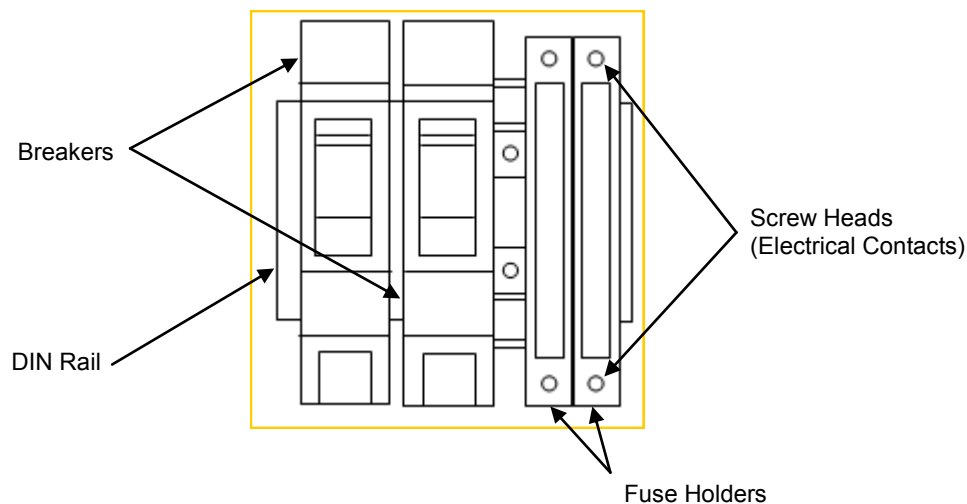

Example of Breakers and Fuse Holders mounted on DIN Rail inside a control Panel.

Note: Quickdraw XR Conveyors with a standard 10W Motor should draw no more than 0.75 amps unloaded.

Integral Motor Controller

Introduction:

Quickdraw's brushless DC (BLDC) motor controller commutates power into a standard three phase brushless (BLDC) motor up to a 10-watt motor. The BLDC controls (i.e. speed, direction, enabling) can be set by using jumpers or by giving external signals to connector P1.

Controller Dimension Diagram

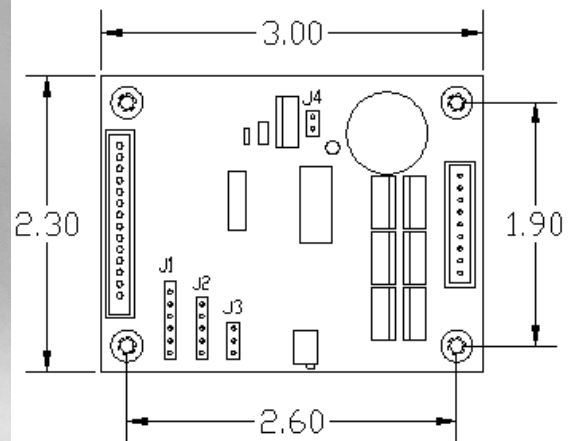
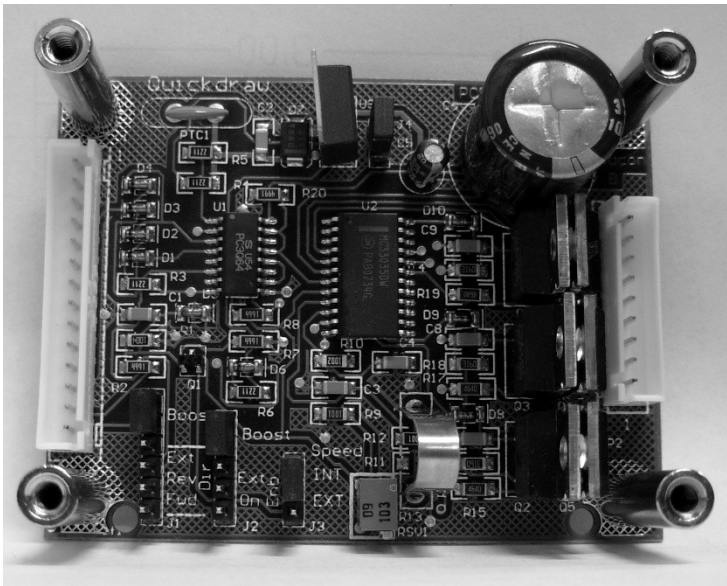

(6-32 tapped standoff on board)

Connections: Power and Control Signals, Brushless Motors and Hall Sensors.

Brushless Motors:

Brushless DC motors have eight (8) wires; three (3) phase lines to the motor, three (3) Hall sensor lines, and sensor power and common. Also BLDC motors come with two sensor configurations. 60, and 120 degrees and is connected to P2.

Quickdraw designed this controller to power Japan servo 3W and 10W motors, although other motors can be driven with this controller.

Motor Sensor Spacing:

Quickdraw's BLDC controller is shipped ready for 120-Degree sensor spacing. *(Note: The Japan Servomotors supplied on most Quickdraw conveyors use 120 Degree sensor spacing)* However, if 60-degree spacing is desired, remove the jumper across J4.

Power Requirements:

The power is supplied to this card using Pin 1 and Pin 14 on connector P1. The 24V input signal should be fused with a 1-amp slow blow fuse. The power should be off until the hookup procedure is complete and you are ready to run.

Integral Motor Controller, Cont'd

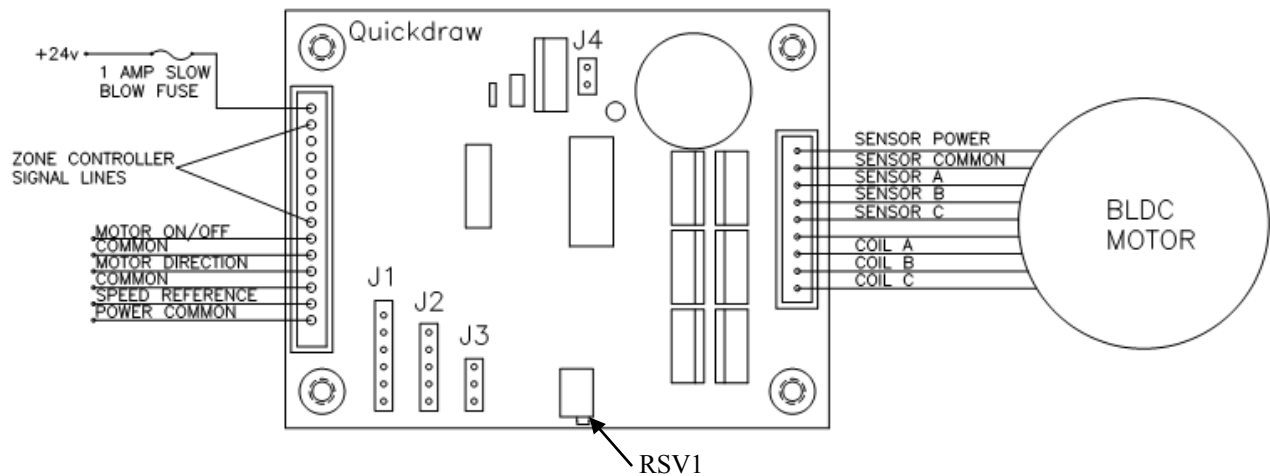

Motor Speed Control:

Quickdraw's BLDC controller comes with two speed control options. The different control options can be selected by changing the position of jumper J3 on the motor controller board. When internal speed control is selected with the jumpers, the motor references the multi turn pot (RSV1) on the controller board for speed. The speed can be increased or decreased by turning the pot with a non-conducting screwdriver.

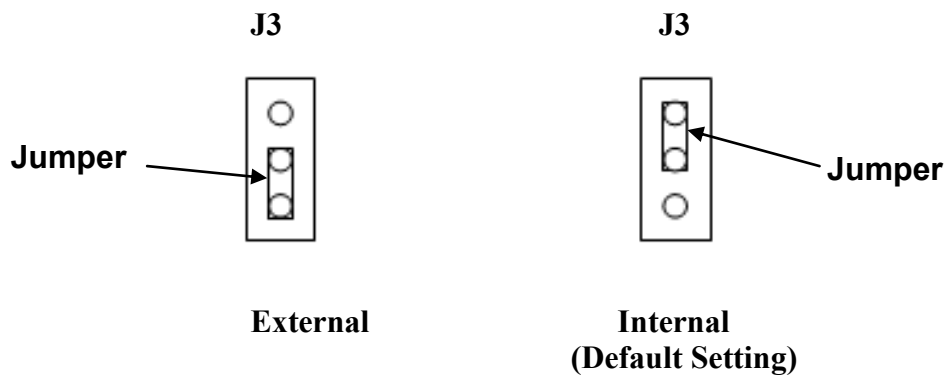

Motor Controller speed control options.

When the external speed control is selected, the speed pot is disabled and the motor gets its speed reference from an external 2-5V signal. This signal should be reference to the controller's common.

Motor Enabling Control:

Quickdraw's BLDC controller has three modes for controlling the motor: boost, external enable, and always on.

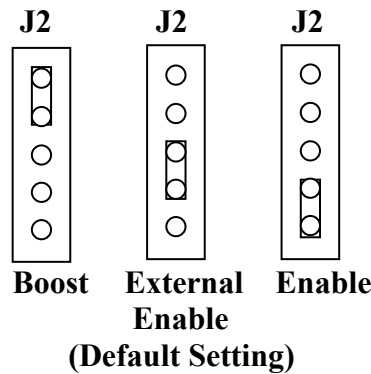

Motor Controller Enabling Options.

Motor Boost mode uses control signals from another controller and amplifies those signals for use on higher wattage motors. These connections are made through P1.

Motor External Enable mode uses the control signal on P1-9. This pin is brought to common P1-10 through a jumper wire, switch, relay, or an open collector NPN transistor.

Motor Enable mode; the motor is always on.

Unless specified otherwise by the customer, the default setting for this jumper is “External Enable”.

Motor Directional Control:

Quickdraw's BLDC controller has four modes for controlling the motor direction: boost, external direction, always forward, or always reverse. This controller is not designed for plug reversing. Damage to the controller could happen by not stopping it first.

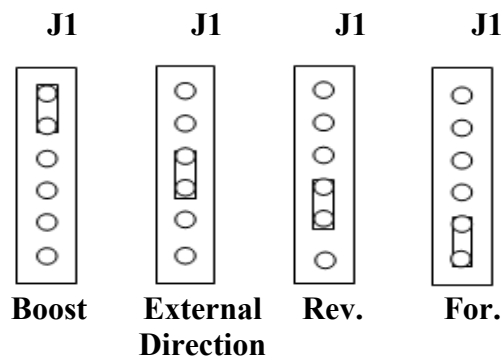

Motor Controller Directional options.

- Motor direction is specified by the Customer.
- Motor Boost mode uses directional control signals from another controller and amplifies those signals for use on higher wattage motors. These connections are made through P1.

- Motor External Direction mode uses the control signal on P1-11. This pin is brought to common P1-12 through a jumper wire, switch, relay, or an open collector NPN transistor.
- Motor Forward mode, the motor will always rotate clockwise (view facing shaft end).
- Motor Reverse mode, the motor will always run counterclockwise.

SPECIFICATIONS:

BOARD OUTSIDE DIMENSION.....	2.3" x 3"
MOUNTING HOLE DIMENSION.....	1.9" x 2.6"
INPUT VOLTAGE	24Vdc
OUTPUT VOLTAGE	0 to 24Vdc
MOTOR HALL SPACING (jumper selectable)	60° to 120°
LOAD CURRENT (continuous)	2.5 Amps continuous
SPEED RANGE	0-100%, full range
INPUT CONNECTIONS	14-pin JST
OUTPUT CONNECTIONS	9-pin JST
SPEED COMMAND SIGNAL	2-5Vdc
DIRECTIONAL COMMAND SIGNAL	Switched to common
MOTOR CONTROL SIGNAL	Switched to common
OPERATING TEMPERTURE	32° - 95° F
INTERNAL VOLTAGE SUPPLY (for hall sensors)	6.25 Volts

Conveyor Interface Connector:

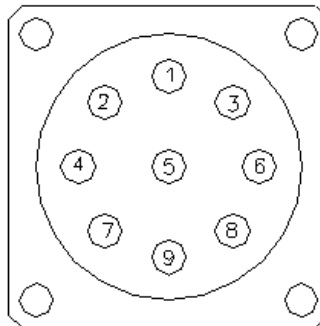

AMP 11-9 Connector
AMP PN: 206486-1

PIN #	DESCRIPTION	STANDARD CABLE COLOR	FLEX CABLE COLOR
1	+24V Source	Orange	Pink
2	Motor ON/OFF	Brown	Brown
3	Motor ON/OFF Common	Red	Red
4	Motor Direction	Black	Gray
5	Motor Direction Common	White	White
6	Speed Reference (0-5VDC)	Blue	Blue
7	Source Common	Green	Green
8	N/C	X	X
9	N/C	X	X

Motor Control Card Wiring Diagram

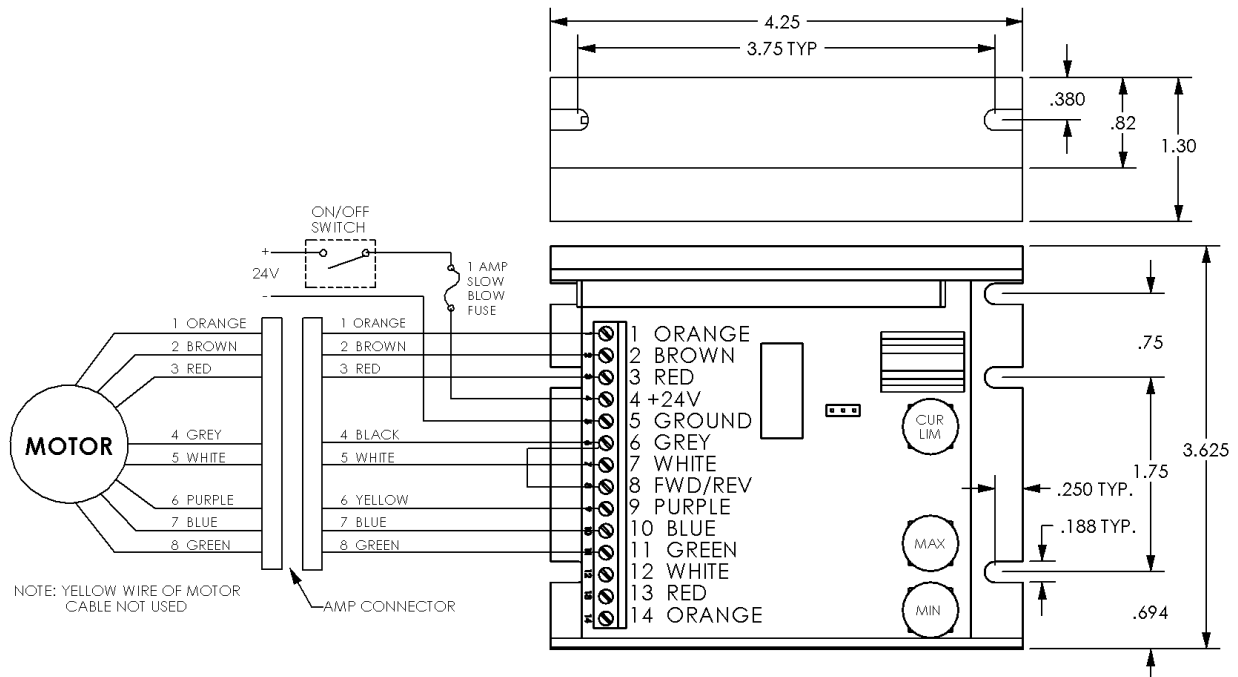

Wiring Diagram For The Dart 700BDC

Please Note: The enclosed Speed Pot is connected as follows:
 White to 12; Red to 13; and Orange to 14. To eliminate the Speed Pot, jumper Terminals 12 & 13 and set speed using on-board controls.

Motor Cable Wiring Guide

Pin	Ribbon Cable	Pin	8 Conductor Cable
1	Orange	1	Orange
2	Brown	2	Brown
3	Red	3	Red
4	Grey	4	Black
5	White	5	White
6	Purple	6	Yellow
7	Blue	7	Blue
8	Green	8	Green

Note: the Yellow Wire is Not Used on the Ribbon Cable.

Procedure to Change direction— Dart DC Brushless 700BDC Card:

- 1) Unplug power to Conveyor.
- 2) Locate the Motor Control Card that is operating in the wrong direction.
- 3) Turn off power.
- 4) Unplug the Conveyor Control Box from electrical power.
- 5) Check the Control Card for a wire jumper (usually orange in color) connecting Terminals #6 and #8.
- 6) If there is a jumper wire, remove the wire to change the direction of flow.
- 7) If there is no jumper, insert a wire jumper to change the direction of flow.
- 8) Plug in the Conveyor Control Box.
- 9) Turn on the power.

Setting Conveyor Speeds

Unless otherwise requested, Quickdraw sets all Conveyor Speeds at 60 ft./min. for all Conveyor Systems that include Conveyor Control Boxes. Quickdraw does this to standardize its conveyor performance data. The Motor Cards used on most applications come with Speed Potentiometers (Speed Pots) that can either be used or discarded. Most customers choose not to use the Speed Potentiometers, but rather set speed with Min/Max Speed Pots directly attached to the board.

How To Determine Conveyor Speed

Procedure:

- 1) Place a piece of non-reflective tape around the Drive Roller. * *This is done to ensure that the Tachometer is reading only the reflection of the special reflective tape.*
- 2) Place a small piece of reflective tape onto the other tape.
- 3) Turn on the conveyor.
- 4) Measure the rpm with a Handheld Optical Digital Tachometer, such as the "AMETEK Model 1726 Optical Digital Tachometer".

How To Convert Linear Distance/Minute to Target RPM

Procedure:

- 1) Establish the needed conveyor flow rate. * *For example: 60 ft/min.*
- 2) Determine the diameter of a Roller. * *The diameter of a standard XR Roller is 1.25".*
- 3) Use the following formula to determine the target rpm:
 - Target RPM = Linear Speed (ft/min) / { π *roller diameter (in feet)}
 - Target RPM = 60 ft/min. / π * (1.25"/12"/ft)
 - Target RPM = 60 ft/min. / π * 0.104 ft.
 - Target RPM = 60 ft/min. / 0.327 ft.
 - Target RPM = 183

Procedure For Conveyors Equipped With Dart 700 BDC Control Cards:

With Speed Pot:

- 1) Turn the dial on Speed Pot until the tachometer reads target rpm.
- 2) If unable to achieve target rpm, adjust the white Min and Max dials found on the Motor Control Card until the target rpm can be achieved within the range of the Speed Pot.

Without Speed Pot:

- 1) Adjust the white Min and Max dials found on the Motor Control Card until the target rpm can be achieved.

Phase Considerations

For most applications, Quickdraw Systems uses low voltage, Brushless DC 3-Phase Motors and Control Cards. Occasionally, a faulty phase may be the problem. Signs of a bad phase include but are not limited to:

- a) Intermittent Motor Failure.
- b) The ability to start the Motor by turning the Drive Pulley after initial powering-up of the Conveyor. After the Motor has been finger started, the Motor turns on its own, but again may intermittently have a start-up problem.

To remedy this situation, follow the Electrical Troubleshooting guide on the following page. Make certain to turn the Conveyor on and off multiple times to make sure that the real cause of the problem is found.

Electrical Troubleshooting

Procedure:

- 1) Check all electrical connections. Make sure that all plugs are connected properly.
- 2) Make sure that it is an electrical problem by eliminating the Conveyor as a possible cause of failure:
 - a) Measure the current draw (See Page 12).
 - b) Hand power the Conveyor.
 - c) Attach the Conveyor to a Motor Cable that is connected to a different, functioning Motor Control Card. * *Use a different Conveyor Control Box if possible.*
 - d) Measure the current draw.
- 3) If the Conveyor turns by hand, and operates within an acceptable current draw range when connected to a different Motor Control Card, the problem lies somewhere in the original electrical system.

Possible causes include:

 - a) Electrical connections.
 - b) The Motor.
 - c) The Motor Cable.
 - d) The Power Supply.
- 4) To check the Motor, plug the electrical system in question into a different Conveyor. If the new Conveyor operates properly, the Motor on the original Conveyor is probably the cause and should be replaced.
- 5) To check the Motor Cable, switch Cables with a Conveyor that is operating properly. If the problem disappears, check the original Cable for bad electrical connections or cuts. If the original Cable cannot be repaired, then it must be replaced.
- 6) Unplug the Conveyor Control Box and check for loose connections or cut wires within the Control Box. Be careful not to create additional problems by pulling too forcefully on the wires. If you believe that you have found loose wiring and have taken steps to reconnect them properly, plug in the Control Box and measure the current draw of the original system. If the current draw is within the acceptable range, you have fixed the problem. If not, proceed to step #7.
- 7) If you still have not found the problem, replace the Motor Card using the Wiring Diagram on Pages 14 or 16 & 17 as a guide.
- 8) If this does not eliminate the problem, please call a Quickdraw Systems representative for support at 1-800-473-8837 or (952) 935-6921.

Troubleshooting

Important: *When performing any maintenance, make certain that the Drive Assembly is free to turn before applying power to the Motor.*

Problem	Possible Cause(s)	Solution
Conveyor Rollers are not turning.	a) Is the Motor turning? b) Are the Covers on tightly?	a) If not, refer to Motor problems. b) Loosen and retighten the Covers to ensure that the Guides are in contact with Timing Belt.
The Motor is not turning.	a) Is a fuse blown? b) Is the speed adjustment turned down? c) Is there a faulty connection? d) Is the Motor Control Card receiving 24VDC?	a) Replace blown fuse. b) Adjust the speed on the Motor Control Card. c) Check to see that the Motor is plugged in and no wires are loose on the Motor Control Card. d) Use a volt meter and check the potential across terminal numbers 4 and 5 of the Control Card.
The Motor will turn, but only when started by hand.	a) If the Motor will not start on its own, but will run if manually started, the Motor Control Card is likely at fault. b) Is it a faulty Motor or Motor Control Card? c) Is it a bad wire connection?	a) Replace the Control Card. b) Try another Motor on this Control Card and/or this Motor on another Control Card. Replace the defective component. c) Check the connections between the Motor Control Card and the Motor. Repair any loose connections.
Motor Fuses continually blow. (High Current)	a) Is the Conveyor assembled correctly? b) Is it a bad Motor or Motor Control Card?	a) Check that the Drive Assembly turns easily by hand. b) Try another Motor on this Control Card and/or this Motor on another Control Card. Replace the defective component.

XR Conveyor Components Parts List

<u>Part Number</u>	<u>Description</u>
400623	BEARING,FLANGED,MODIFIED
404404	BLOCK,TENSIONER
404410	XR ROLLER SHAFT
600906	TENSIONER ASSY,XR
600907	DRIVE PULLEY ASSY,XR
600911	PULLEY ASSY,XR,STANDARD
910097	SCR,M4 X 10,FHCS,SS
910921	SCR,M4 X 3,SSS,SS,CUP
910929	SCR,M5 X 6,SSS,HALF DOG
930047	NUT,Z,M4
404400-(LENGTH)	RAIL,LOWER,XR,LEFT (LARGER BOTTOM PIECE)
404401-(LENGTH)	RAIL,LOWER,XR,RIGHT (LARGER BOTTOM PIECE)
404402-(LENGTH)	RAIL,UPPER,XR (TOP PIECE)
404403-(LENGTH)	PRODUCT GUIDE,XR (PLASTIC STRIP)
600912L	MOTOR KIT,DD,XR,LEFT
600912R	MOTOR KIT,DD,XR,RIGHT
960464-(LENGTH)	BELT,TIMING,XR,WELDED

Gauges & Tools

600964	FORK,XR ROLLER REMOVER

Additional Support:

Contact Quickdraw Systems if you have any questions or need parts that aren't listed on this page.

Phone: 1-800-473-8837 or (952) 935-6921

Fax: (952) 933-5803

E-mail: Info@qdraw.com